

CSERIES

AMPLIFIER

AUDIO
SYSTEM

the sound

**HIGH-PERFORMANCE
CAR- AMPLIFIER**

OWNER'S MANUAL



CE

CO 95.2

CO 65.4

Congratulations on your purchase of your new **C SERIES** amplifier.

Before installation your power amplifier, we recommend to read the manual's owner carefully and to follow the instructions regarding connection and fitting exactly.

We advice to accomplish the installation by an authorized service center, because a professional fitting and connection is the requirement for further warranty adjustments.

CO 95.2

- * 2-Channel High Power Class-AB amplifier with SMD technology
- * MOS-FET PWM Power Supply
- * Stable into 2 ohm stereo per channel and 4 ohm bridged mode
- * Variable switchable Low Pass Filter from 30 to 300 Hz
- * Variable switchable High Pass Filter from 30 to 300 Hz
- * Input Sensitivity: variable 200 mV maximum to 8 V minimum
- * **Multi-Way Protection Circuitry**: overheating, overcurrent, short circuitry and speaker DC protection
- * Operating Voltage : DC 10 ~ 16 V power input
- * Wired Remote Control **RTC** (optional)
- * High-Power-Input (normally original radio) with automatically „Turn-On“
- * Adaptercable **HLAC** and **RCA HI** (optional)

CO 65.4

- * 4-Channel High Power Class-AB amplifier with SMD technology
- * MOS-FET PWM Power Supply
- * Stable into 2 ohm stereo per channel and 4 ohm bridged mode
- * Variable switchable Low Pass Filter from 30 to 300 Hz
- * Variable switchable High Pass Filter from 30 to 300 Hz
- * Input Sensitivity: variable 200 mV maximum to 8 v minimum
- * **Multi-Way Protection Circuitry**: overheating, overcurrent, short circuitry and speaker DC protection
- * Operating Voltage: DC 10 ~ 16 V power input
- * Wired Remote Control **RTC** (optional)
- * High-Power-Input (normally original radio) with automatically „Turn-On“
- * Adaptercable **HLAC** and **RCA HI** (optional)

CO 95.2 / CO 65.4

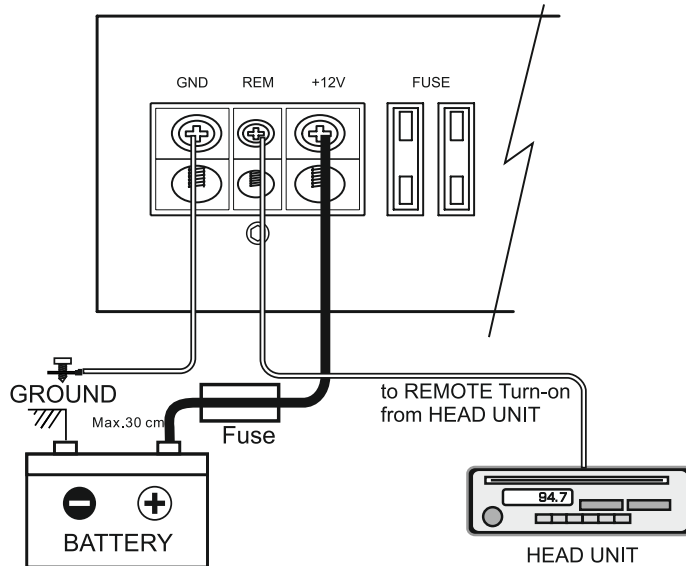

1. Battery disconnection

First disconnect the power supply of the vehicle. This works out the best by removing the ground cable of the battery.

2. Ground connection

Connect the GND (ground) connection of the amplifier with the car chassis. Keep this cable as short as possible (not longer than 50 cm) and use a suitable cross section (AWG size 8 - 6). Make sure, that the connection with the vehicle chassis is free of paint, dirt and dust.

3. +12 V Power connection

Connect the +12 V contact of the amplifier with the supply cable via a fuse directly to the vehicle battery. Keep in mind, that the length of the cable from fuseholder to vehicle battery has to be a maximum of 30 cm.

Requirement for a perfect function of the amplifier is a qualitative high end fuse holder as well as a suitable cable cross section (AWG size 8 - 6).

This fuse protects the amplifier and the vehicle against the possibility of a short circuit in the power cable.

4. Remote connection

Connect the REM-terminal of the amplifier to the remote-output (automatic 12 V antenna-output) of the head unit. Therefore use a 0,5 - 1,5 mm power cable.

⚠ Caution ⚠

Please follow the instructions during the installation of your amplifier:

- Take care of a professional attachment. Pay attention, that no electrical cable, gas tank, hydraulic brakes or other components get damaged.
- There has to be enough cooling and air circulation. Avoid the installation in small closed boxes or close to heating parts.
- Protect the amplifier from fluids, wetness, heat and foreign material as well as from other influences.
- The amplifier is only to be built into vehicles with a 12 V DC power supply.
- Never install the power supply cable with other original wires of the vehicle (gas cables), fan motors, brand control moduls etc.
- Install the signal cable (cinch cable) as well as the speaker cable far away of the power cables to avoid troubles with the music signal.
- The cables of your amplifier have to be installed, so that there is no danger of binding, squeezing or breaking.

CO 95.2

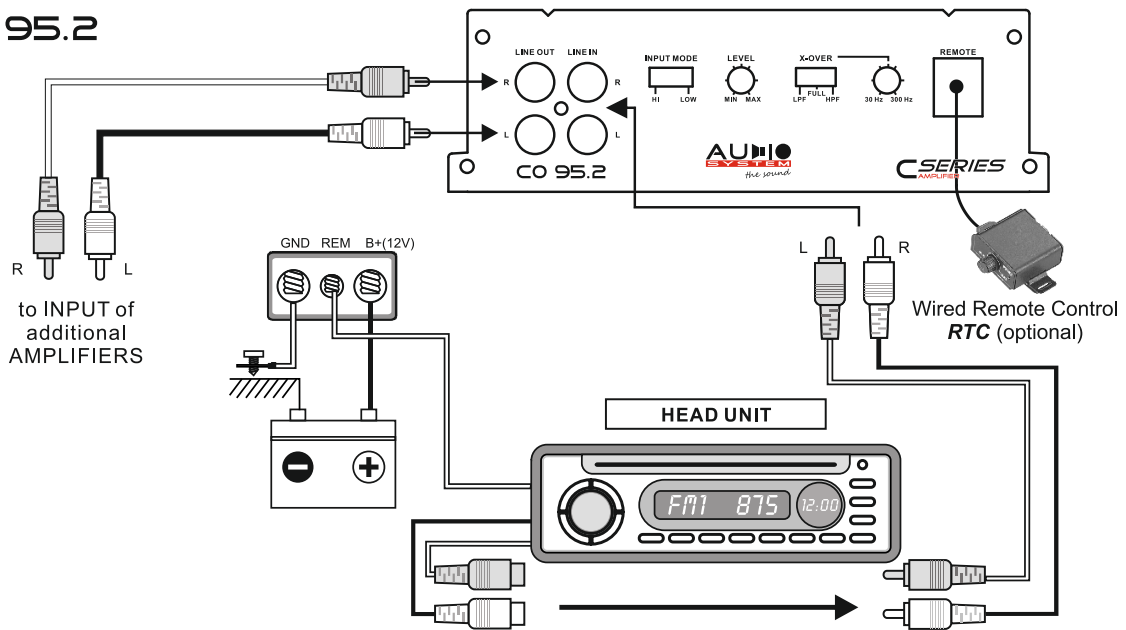

CO 65.4

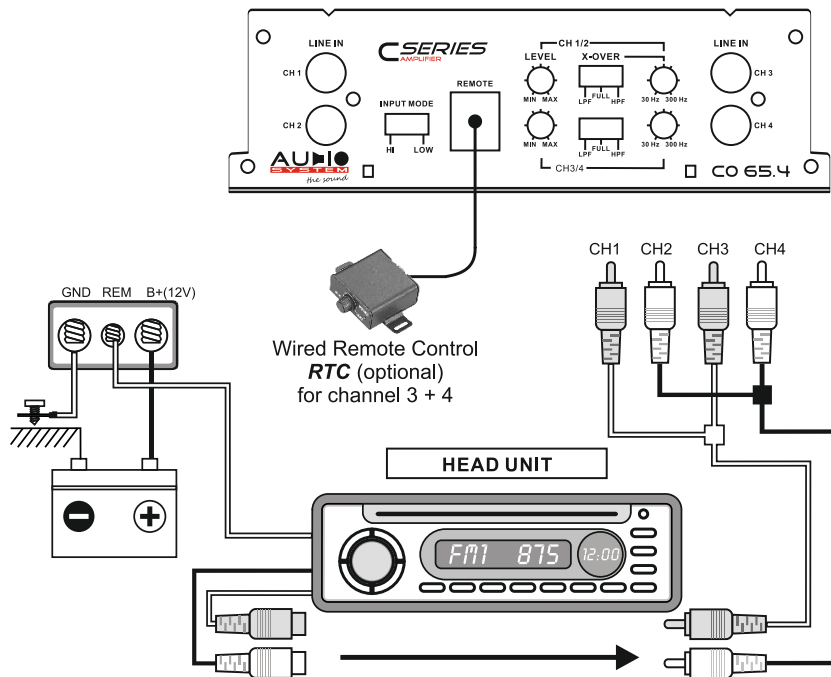

The **C SERIES** amplifier offers RCA-Inputs, which are connected through cinch cables with the preamplifier-outputs of the head unit. If the head unit (OEM-RADIO) has no RCA-Output, than it is possible to connect the speaker output direct to RCA/Cinch-Input. Input Mode has to be switched on „HI“. If signal is presented, the amplifier automacally turns on. Adaptercable **HLAC** and **RCA HI** can be purchased at your specialized dealer.

The RCA-outputs provide the possibility to transfer the signal of the head unit to a 2. amplifier via a cinch cable (not possible for **CO 65.4**).

With the aid of the shiftable high- and lowpassfilter, the gain-controller and the bassboost you are able to adjust the amplifier on to your prepered taste of hearing, the circumstances of the vehicle and to the speakers.

In this regard, **AUDIO SYSTEM GERMANY** recommends to adjust your amplifier through a specialized service center, dealer or a specialist.

SPEAKER CONNECTION

C SERIES
AMPLIFIER

CO 95.2

1-Channel Bridged

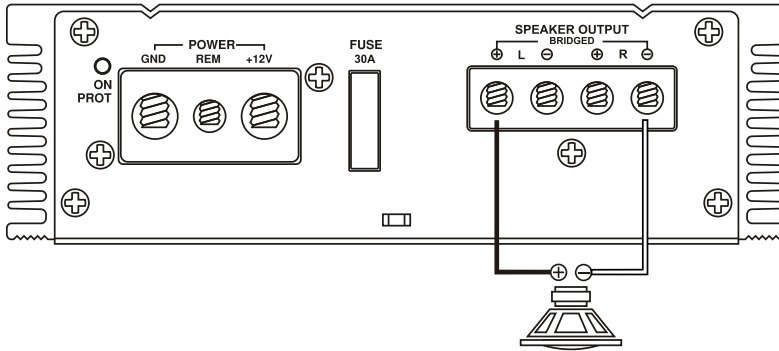

speaker impedance
4 ~ 8 Ohm

2-Channel Stereo

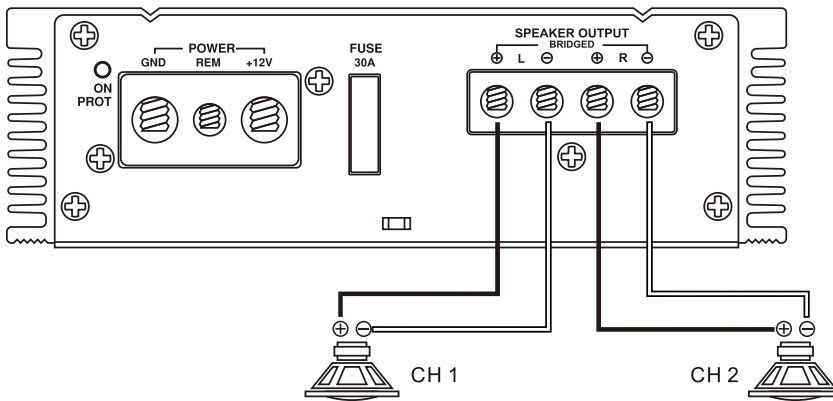

speaker impedance
2 ~ 8 Ohm

Tri-Mode

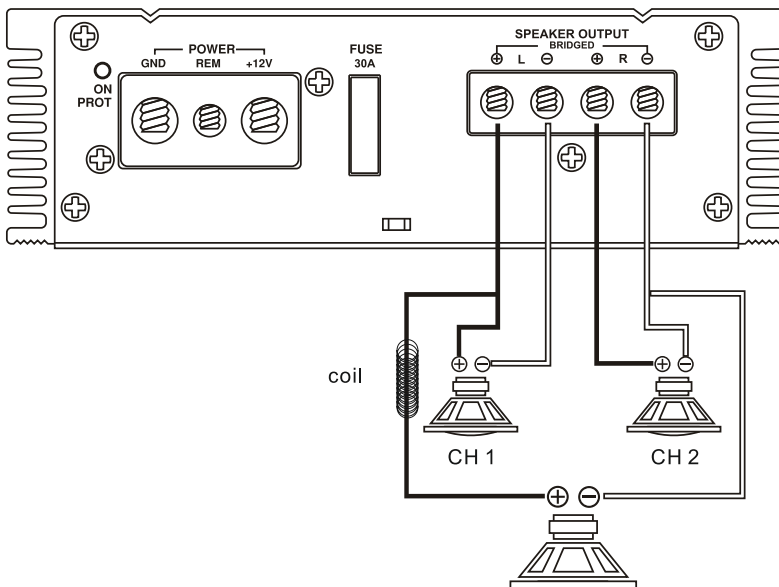

speaker impedance
4 ~ 8 Ohm

CO 65.4

2-Channel Mono

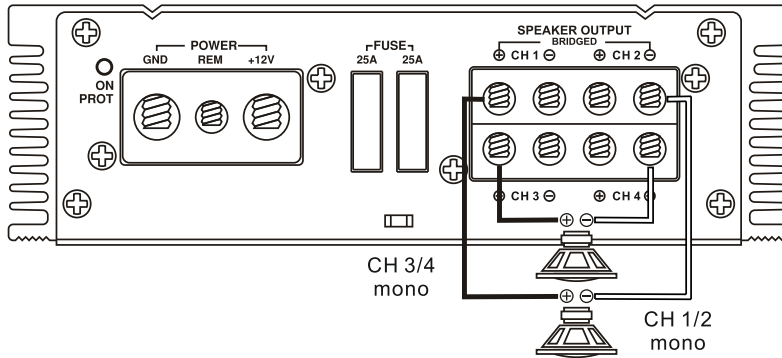

speaker impedance
4 ~ 8 Ohm

4-Channel Stereo

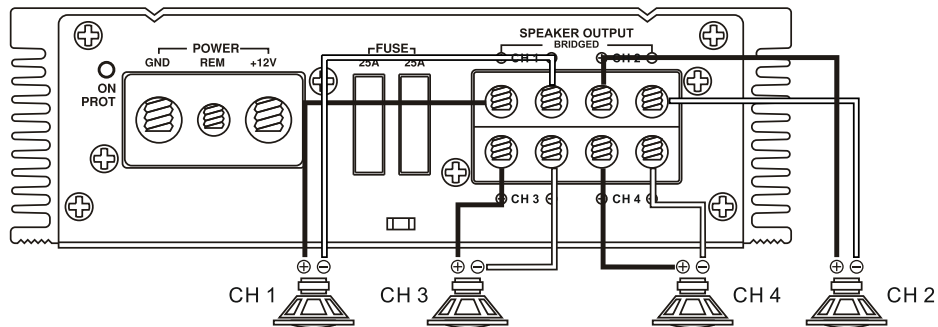

speaker impedance
2 ~ 8 Ohm

2-Channel Stereo + 1-Channel Mono Bridged

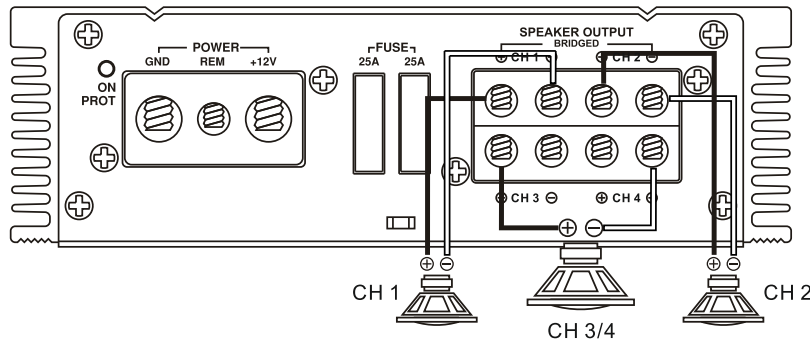

speaker impedance
4 ~ 8 Ohm

This power amplifier is featured with a efficient protection system to prevent any damages like over-heating, overvoltage, short-circuit and DC at the loudspeaker output.

Occuring an error the protection-LED will light in red.

In order to check the problem, first turn down all levels of the head unit, afterwards turn it off.

<p>AMPLIFIER IS NOT POWERED UP, NO LED IS LIGHTENING</p>	<ul style="list-style-type: none"> - ground connection professional connected? - +12V powercable professional connected? - remote cable professional connected? - fuses inserted and alright? - analyze voltage on the amplifier.
<p>PROTECTION LED ILLUMINATES GREEN WHILE AMPLIFIER IS SOUNDLESS</p>	<ul style="list-style-type: none"> - cinch cable alright and professional connected? - loudspeaker professional connected? - head unit alright?
<p>PROTECTION LED ILLUMINATES RED WHEN AMPLIFIER IS POWERED UP</p>	<ul style="list-style-type: none"> - amplifier too hot? - short-circuit at the loudspeaker output? - short-circuit caused by loudspeaker cable with vehicle chassis (ground)? - input voltage too high (e.g.faulty lighting dynamo)?
<p>OVERHEATING (PROTECTION LED ILLUMINATES RED WHEN AMPLIFIER IS POWERED UP)</p>	<ul style="list-style-type: none"> - impedance alright? - loudspeaker error? - adequate airflow of the amplifier? <p style="text-align: center;">! CAUTION !</p> <p>After cooling down, the amplifier turns on automatically.</p>
<p>ERROR IN AMPLIFIER FUSE</p>	<ul style="list-style-type: none"> - ground professional connected? - loudspeaker impedance alright? <p style="text-align: center;">! CAUTION !</p> <p>Make sure when changing fuses to use the same value.</p>
<p>SOUND TOO LOW OR LOW-DISTORTED SOUND</p>	<ul style="list-style-type: none"> - input level control "GAIN" is set to match the head unit? - output level control of the head unit alright? - loudspeaker error? - loudspeaker cable checked? - crossover frequencies has been properly set? <p>(Check head unit, ampliflier, DSP, soundprozessor, equalizer, frequency bandpassfilter...)</p>
<p>HIGH HISS-ENGINE NOISE IN SPEAKERS</p>	<ul style="list-style-type: none"> - ground connection professional connected? - short-circuit caused by loudspeaker cable with vehicle chassi (ground)? - cinhcable (RCA) and/or loudspeaker cabel installed too close to the power connection cable? - cinch ground (RCA) of the head unit alright?

⚠ CAUTION ⚠

Please contact your specialist dealer if the amplifier is still not working after it has been checked with the error list!

For warranty adjustment / repairs the original invoice has to be attached!

Opening the power amplifier is leading to a lost of warranty in either case!

CO 95.2

Power Supply Voltage	10 - 16 V
Rated Power Output at 14,4 V	
-RMS power @ 4 ohm stereo	2x 95 W
-RMS power @ 2 ohm stereo	2x 150 W
-RMS power @ 4 ohm bridged	1x 300 W
Signal to Noise Ratio	>96 dB
Low Pass Crossover	30 ~ 300 Hz
High Pass Crossover / Subsonic filter	30 ~ 300 Hz
Frequency Response	10 Hz ~ 45 KHz (+/-1 dB)
THD@RMS Watts	< 0,048%
Channel Separation	75 dB
Fuse Rating	30 A x 1
Input Sensitivity	200 mV ~ 8 V (+/- 5%)
Dimensions	240(L) x 47(H) x 171(W) mm

CO 65.4

Power Supply Voltage	10 - 16 V
Rated Power Output at 14,4 V	
-RMS power @ 4 ohm stereo	4x 65 W
-RMS power @ 2 ohm stereo	4x 105 W
-RMS power @ 4 ohm bridged	2x 210 W
Signal to Noise Ratio	>96 dB
Low Pass Crossover	30 ~ 300 Hz
High Pass Crossover / Subsonic Filter	30 ~ 300 Hz
Frequency Response	10 Hz ~ 45 KHz (+/-1 dB)
THD@RMS Watts	< 0,051%
Channel Separation	75 dB
Fuse Rating	25 A x 2
Input Sensitivity	200 mV ~ 8 V (+/- 5%)
Dimensions	280(L) x 47(H) x 171(W) mm